



32.50 STABILISATION



sateco

NOUS AVONS UN MONDE À BÂTIR



Les 2 types de stabilisation

1. Par portique, voir planche 32.50.13

Stabilisation applicable pour des vents < 85Km/h, conformément à la norme NFP 93.350.
Voir tableau chapitre levage pour connaître les cas d'utilisation des portiques

2. Par lest ou ancrage, voir planches 32.50.05 à 32.50.12

Stabilisation avec ou sans lest, modulable en fonction de la carte des vents (ci-dessous) et selon les préconisations SATECO.

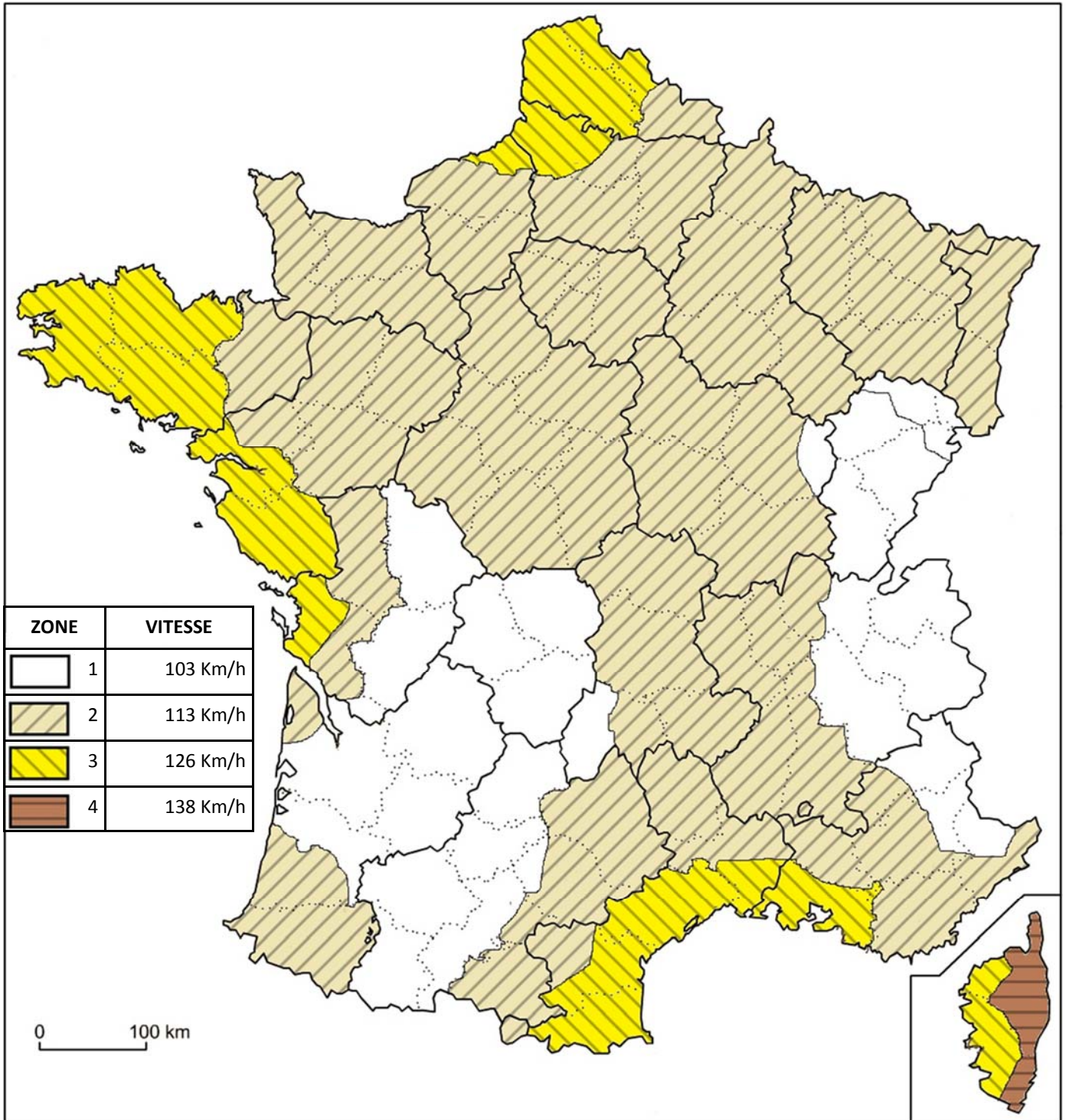

Le stabilisateur T1

D.T. SC 1015 BOX

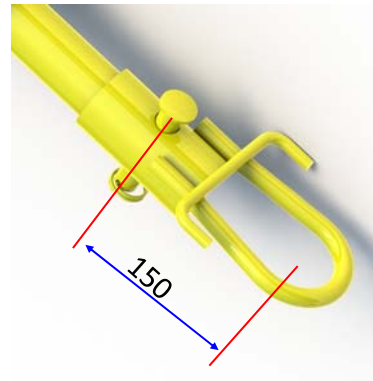

Pied anneau

STABILISATEUR T1:

Longueur du stabilisateur: 1980 à 3500maxi

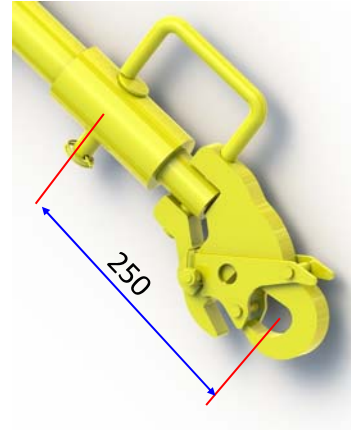
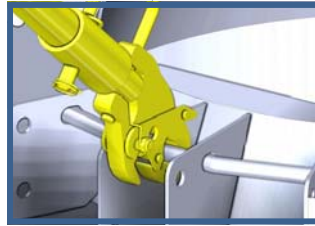

Pied auto.

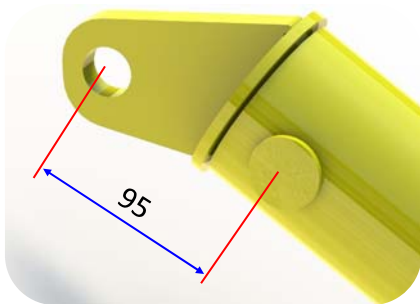
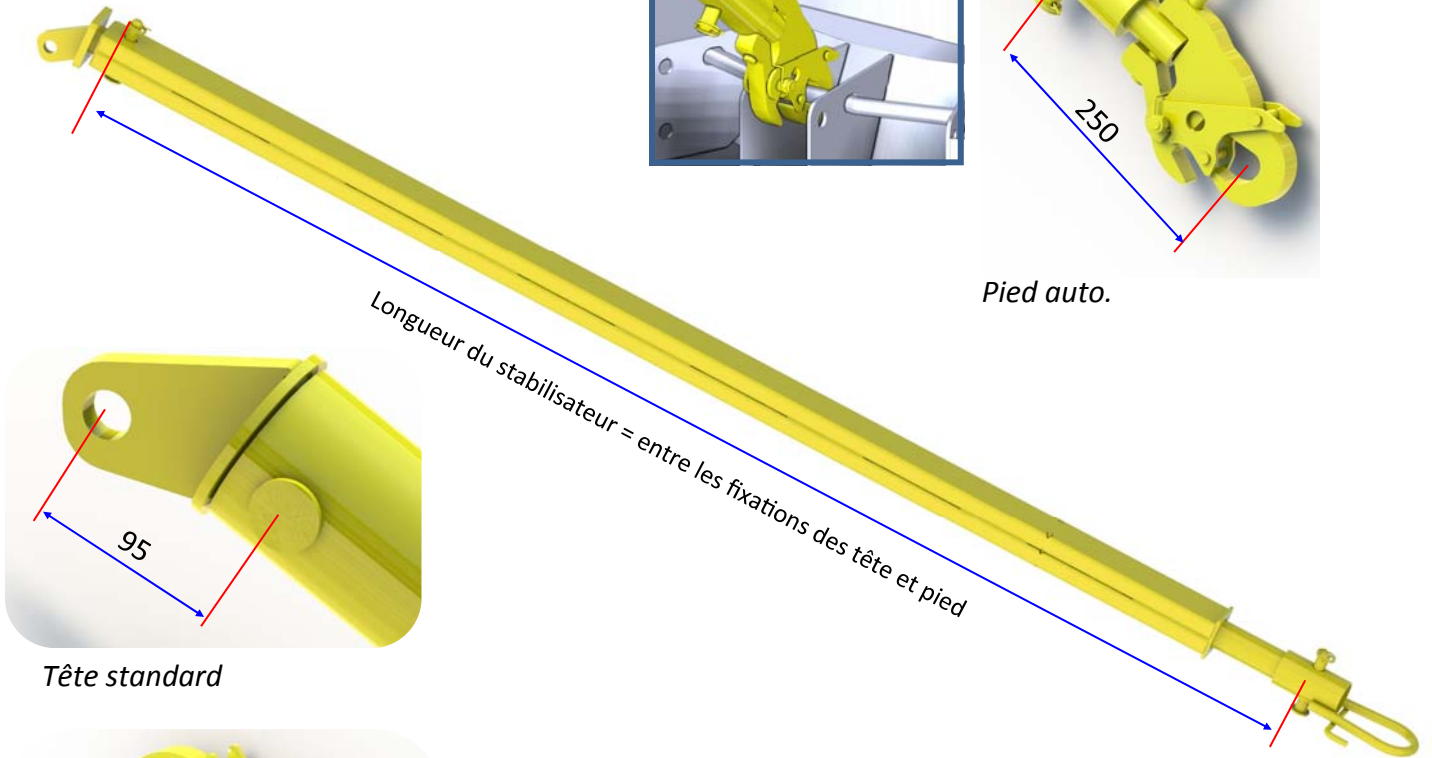

Tête standard

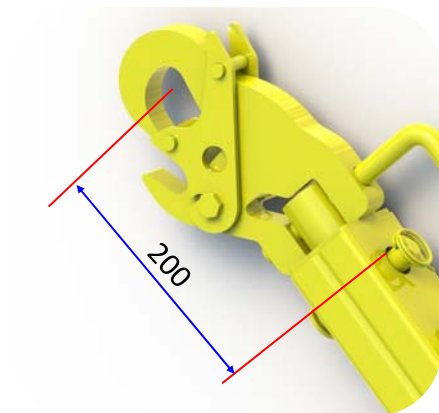

Tête auto.

Remarque: les pieds anneaux et auto. se positionnent sur le sabot de béquille ou sur la chape de la partie basse de béquille lors de la manutention des panneaux. Voir chapitre 32.40 Relevage et manutention.

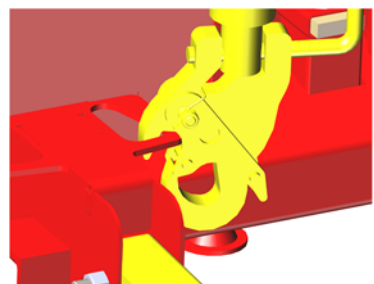
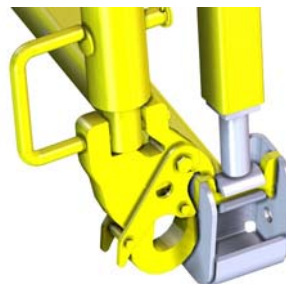

sateco

NOUS AVONS UN MONDE À BÂTIR

Planche: 32.50.01 ind.03

Les stabétails

D.T. SC 1015 BOX



STABETAI T3 :

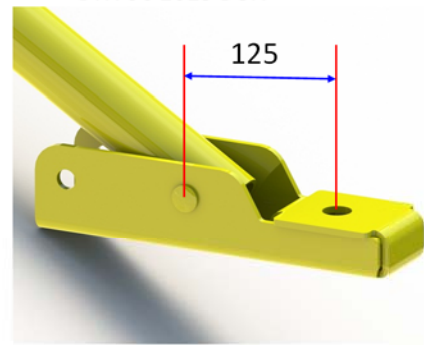
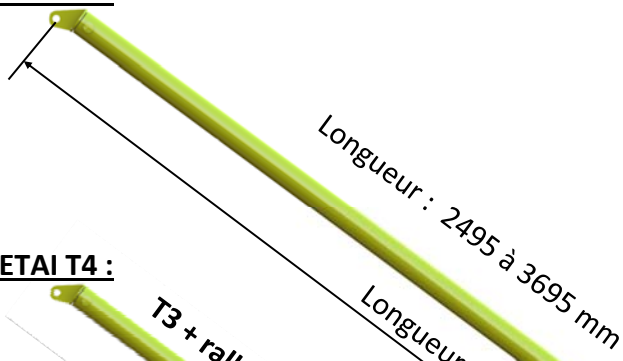

Chape d'ancrage

STABETAI T4 :

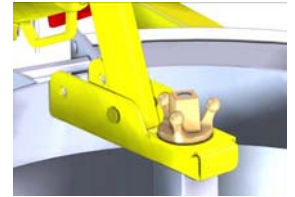
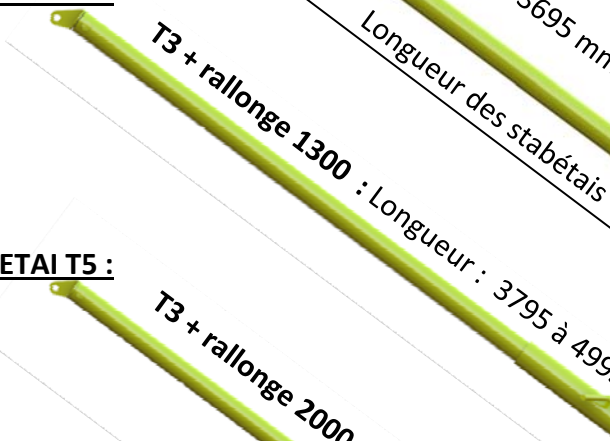

STABETAI T5 :

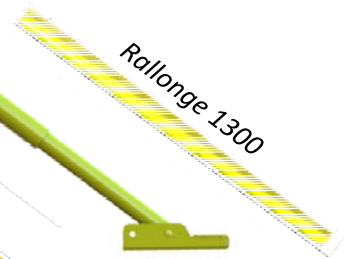
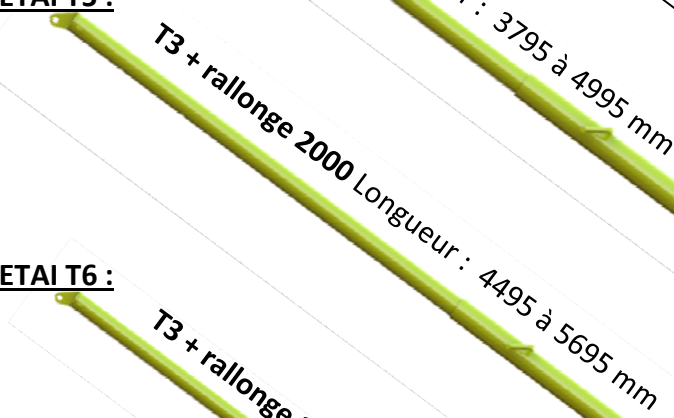

STABETAI T6 :

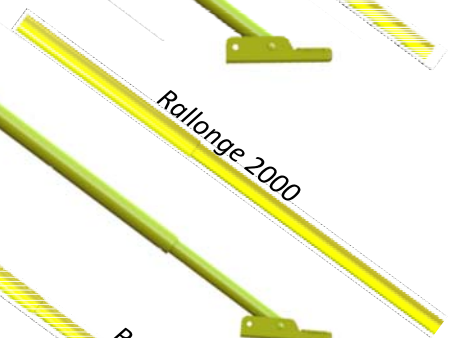
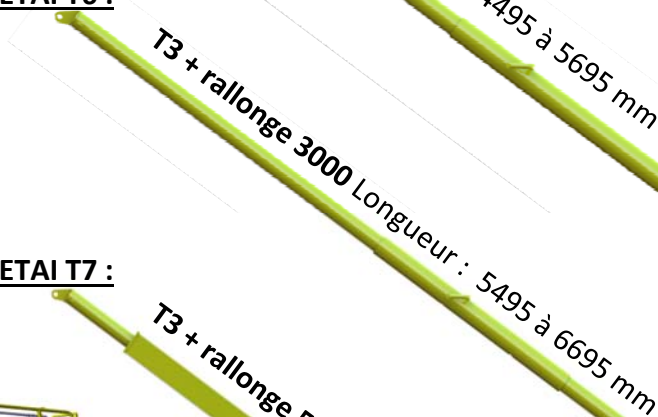

STABETAI T7 :

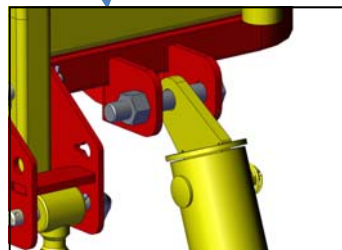
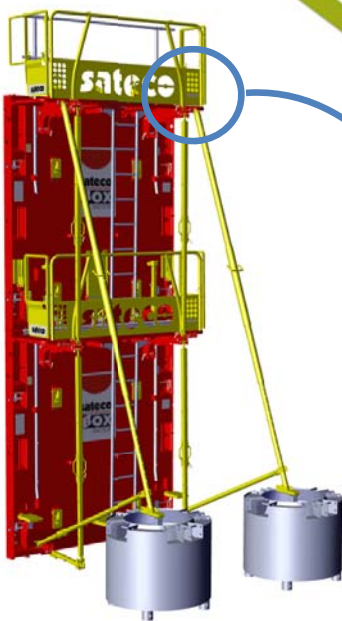
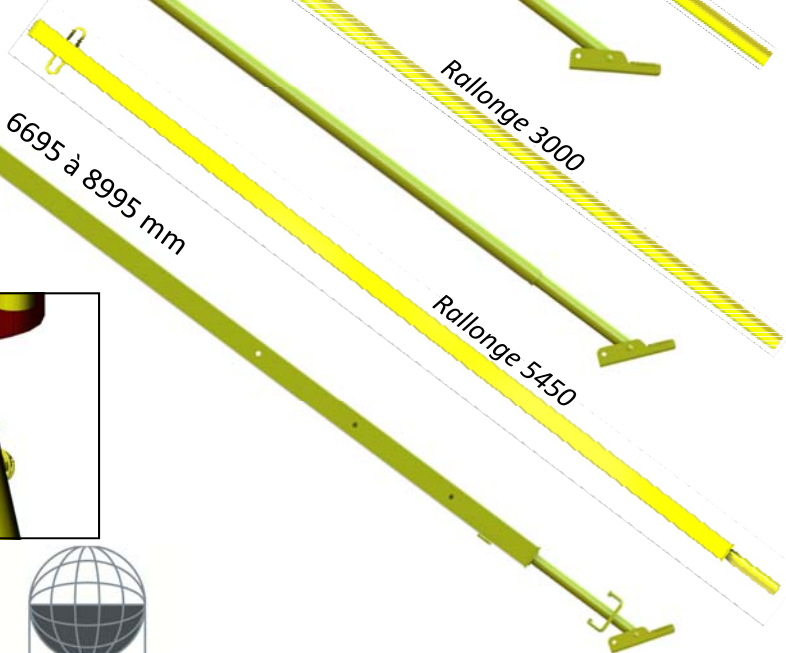

sateco

NOUS AVONS UN MONDE À BÂTIR

Planche: 32.50.02 ind.01



BRACON BAS B1 :

Longueur utile: 2020 à 3320mm

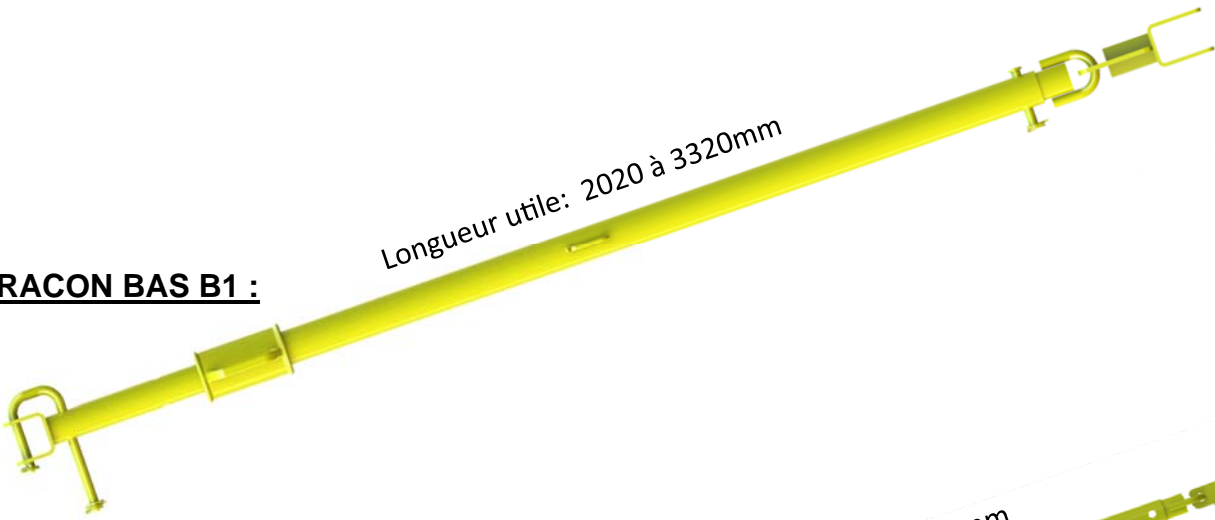

BRACON BAS B2 :

B1 + Rallonge 800 : Longueur utile: 2820 à 4120mm



BRACON BAS B3 :

B1 + Rallonge 800 + Rallonge 800 : Longueur utile: 3620 à 4920mm

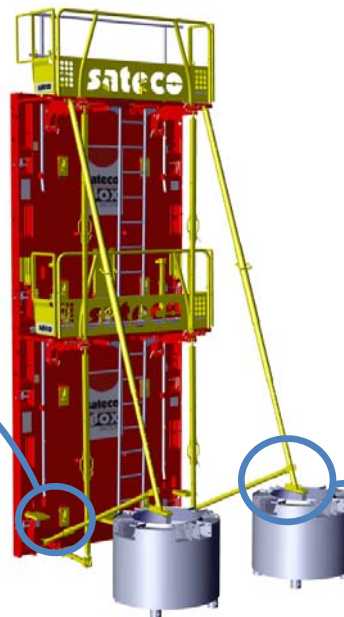
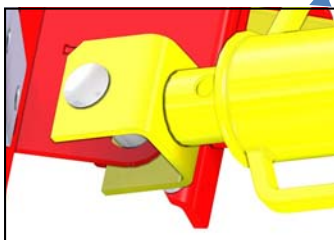
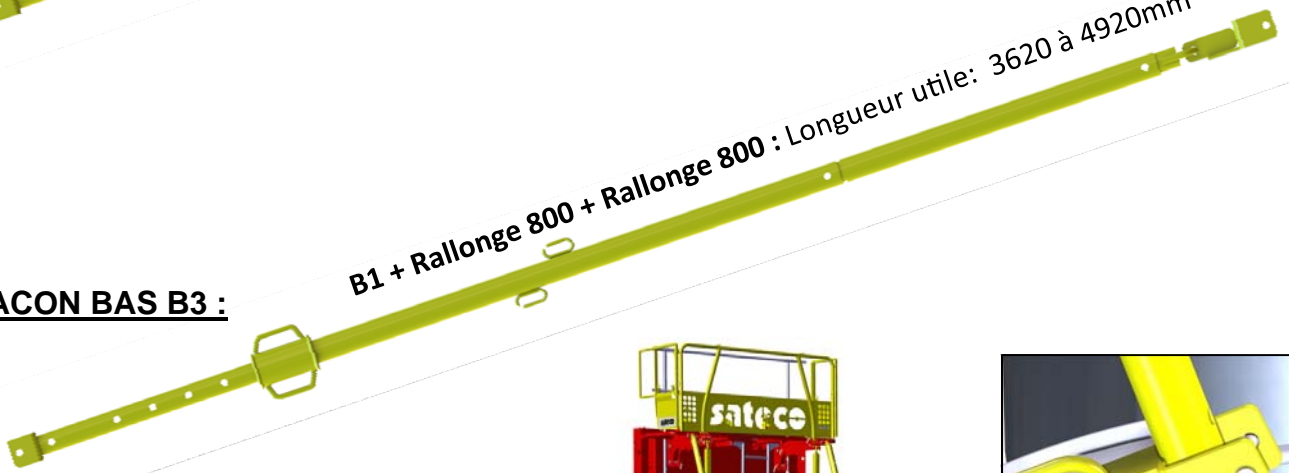

Les lests

D.T. SC 1015 BOX

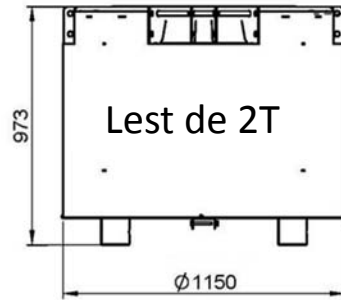
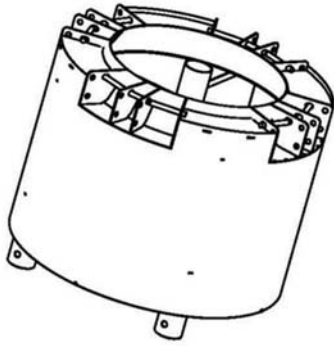
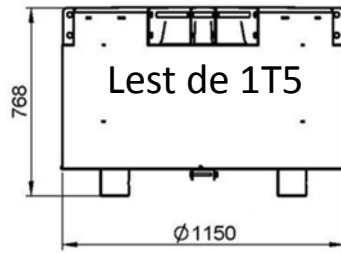
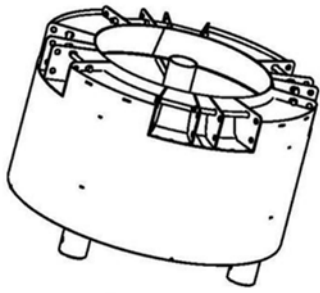

1 pièce de liaison haute

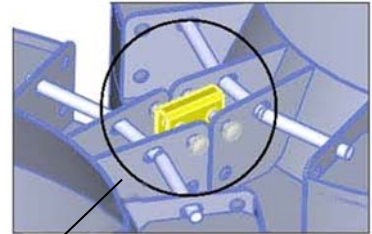

Kit de jonction de lests

2 tiges de liaisons basses

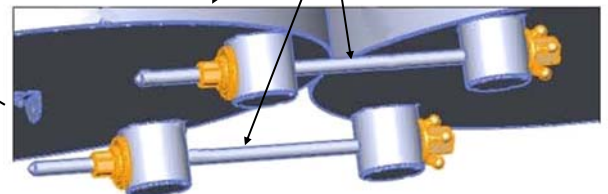

Stockage des lests :

Lest 1.5T : 4 maxi

Lest 2T : 3 maxi

Manutention sur 4 points
CMU 3T

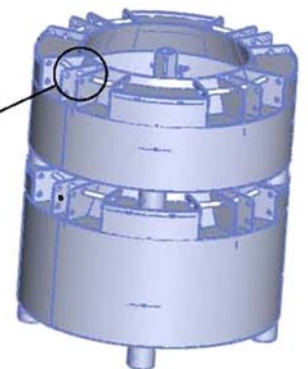
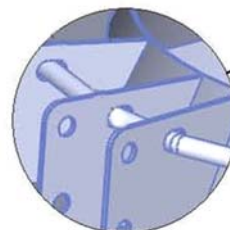

Tige de fixation tout lest

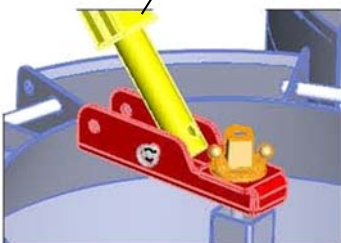
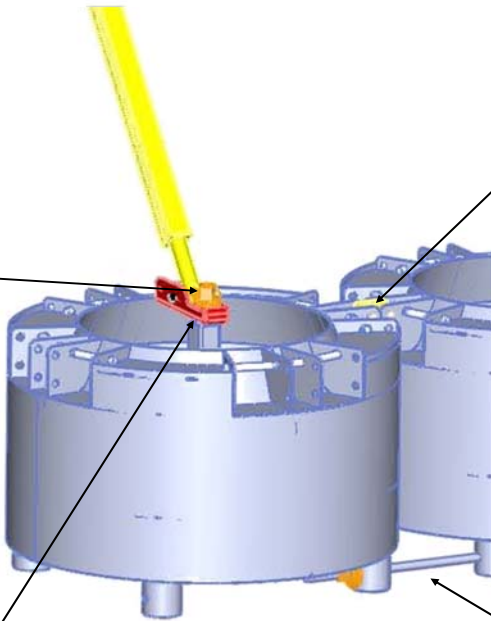
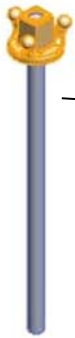

Chape d'ancrage

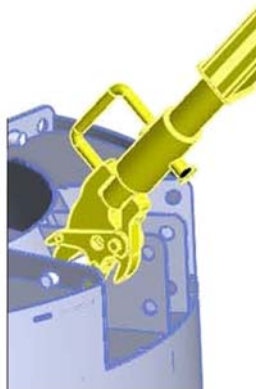

Stabilisateur T1



sateco

NOUS AVONS UN MONDE À BÂTIR

Planche: 32.50.04 ind.01